

Eker 3

Prices of flat screen TVs is going down every single day, while quality, reliability and design know constant improvements.

NorStone offers a new piece that perfectly follows this trend.

Eker 3 is the solution for those who decide not to wall mount their flat screen TV.

Its classical and elegant shapes will ideally blend with any kind of home décor. Its black lacquered shelves will perfectly fit with all the current plasma or LCD finishes.



In the same range:
Eker 5



SPECIFICATIONS

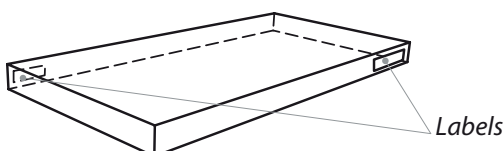
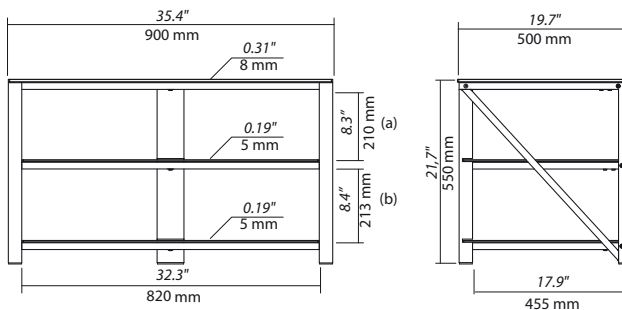
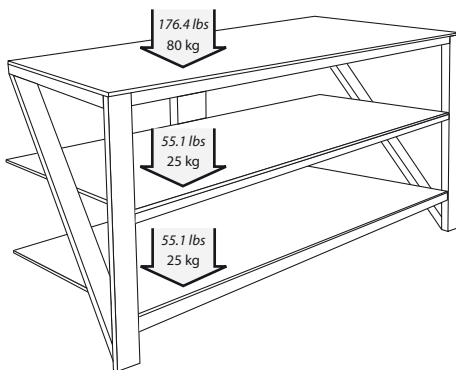

DESIGN

Finish: *Glossy Black/Black*

Structure: Black powder coated steel

Shelves: Black lacquered tempered glass

MAXIMUM LOAD

Upper shelf: 176.4 lbs / 80 kg

Internal shelves: 55.1 lbs / 25 kg

USABLE DIMENSIONS

Overall dimensions (W x H x D):

35.4" x 21.7" x 19.7" / 900 x 550 x 500 mm

Upper shelf (W x D): 35.4" x 19.7" / 900 x 500 mm

Internal shelves (W x D): 32.3" x 17.9" / 820 x 455 mm

Height between shelves: (a) 8.3" / 210 mm

(b) 8.4" / 213 mm

PACKAGING

Delivered disassembled with screws kit, mounting instructions and tools

Quantity/box: 1

Type: Brown cardboard

Dimensions (W x H x D):

38.6" x 5.7" x 23" / 980 x 145 x 585 mm

Gross weight: 61.7 lbs / 28 kg

Net weight: 56 lbs / 25,4 kg

GenCode: 33760108801332